

Product Update

Stepper Motor Harness – Diameter Improvement

MOTORTECH is providing an improved version of the stepper motor harness 31.02.087-10 to be used with MOTORTECH throttle bodies (ITB) and VariFuel2(+) air/gas mixers with 10-pole screw connector. This new version item is delivered since November 1st, 2021.

The improved diameter results in a -25 % smaller bending radius and therefore a higher flexibility for installation. The outer diameter was downsized from 13.5 mm to 10.1 mm.

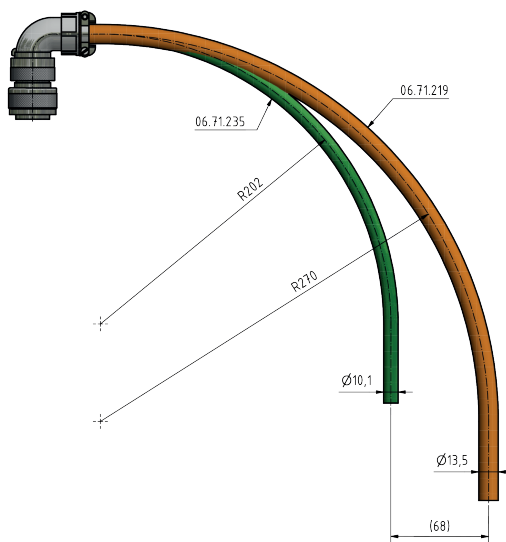

Figure 2: Reduction of bending radius old version to new version

Features

- Number of cores: 4 x 1.5 mm², 6 x 0.25 mm² (fine wire strands of bar copper)
- Total screening: tinned copper wires braiding (0,12 mm)
- Outer diameter: 10.1 ±0.3 mm, PVC, grey
- Temperature range: -40°C – 80°C (fixed installation)
- Flammability: IEC 60332-1
- This cable is conform to the EU-Directives 2014/35/EU (Low Voltage Directive)



Figure 1: stepper motor harness 31.02.087-L

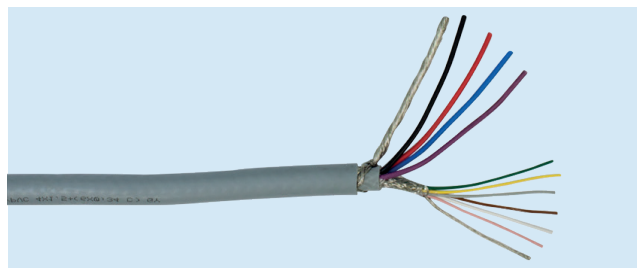

Figure 1: stepper motor harness 31.02.087-L

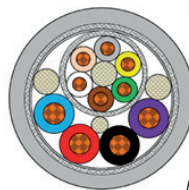

Figure 3: Cross section of harness

Connector		Wire		Signal	
Type	Pole	Type	No./Color	Description	
10-pole socket	A	4 x 1.5 mm ² , 6 x 0.25 mm ²	black	Phase A1	Stepper motor
	B		violet	Phase A2	
	C		red	Phase B1	
	D		blue	Phase B2	
	H		shield	Shield	Encoder
	E		shield	Shield	
	F		white	A	
	G		green	B	
	I		grey	I	
	J		yellow	Power	
-	-	pink	GND	not connected	

DISTRIBUTION

Customers / others	Yes
Representatives and Sales Partners	Yes
OEM partners	No
MOTORTECH subsidiaries	Yes